

4 3 2 1

**SPECIFICATIONS:**

IMPEDANCE: 50 OHMS NOMINAL  
 FREQUENCY RANGE: DC TO 2.4GHz  
 VSWR: DC TO 1GHz AT 1.10:1 MAX.  
 1GHz TO 2.4GHz AT 1.25:1 MAX.  
 POWER RATING: 100 WATTS MAX. @ 40°C.  
 125 WATTS MAX. @ 25°C.  
 COOLING FIN: ALUMINUM, BLACK ANODIZED  
 HEAT SPREADER: ALUMINUM, SILVER PLATED  
 CONNECTORS: IEC 7/16 FEMALE, TRI-ALLOY PLATED  
 OPERATING POSITION: ANY  
 NOMINAL SIZE: APPROX. 8.15" L. X 2.75" SQ.  
 WEIGHT: APPROX. 48 OZ.

REVISIONS		DWG. NO.	100-SA-FFE-XX	SHEET	REV
ZONE	REV	DESCRIPTION	DATE	APPROVED	
	A	ECN #0211	12-15-98	MAJ	

D

D

C

C

B

B

A

A

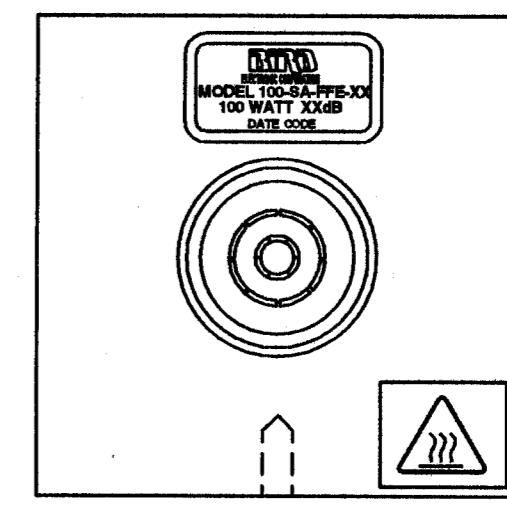
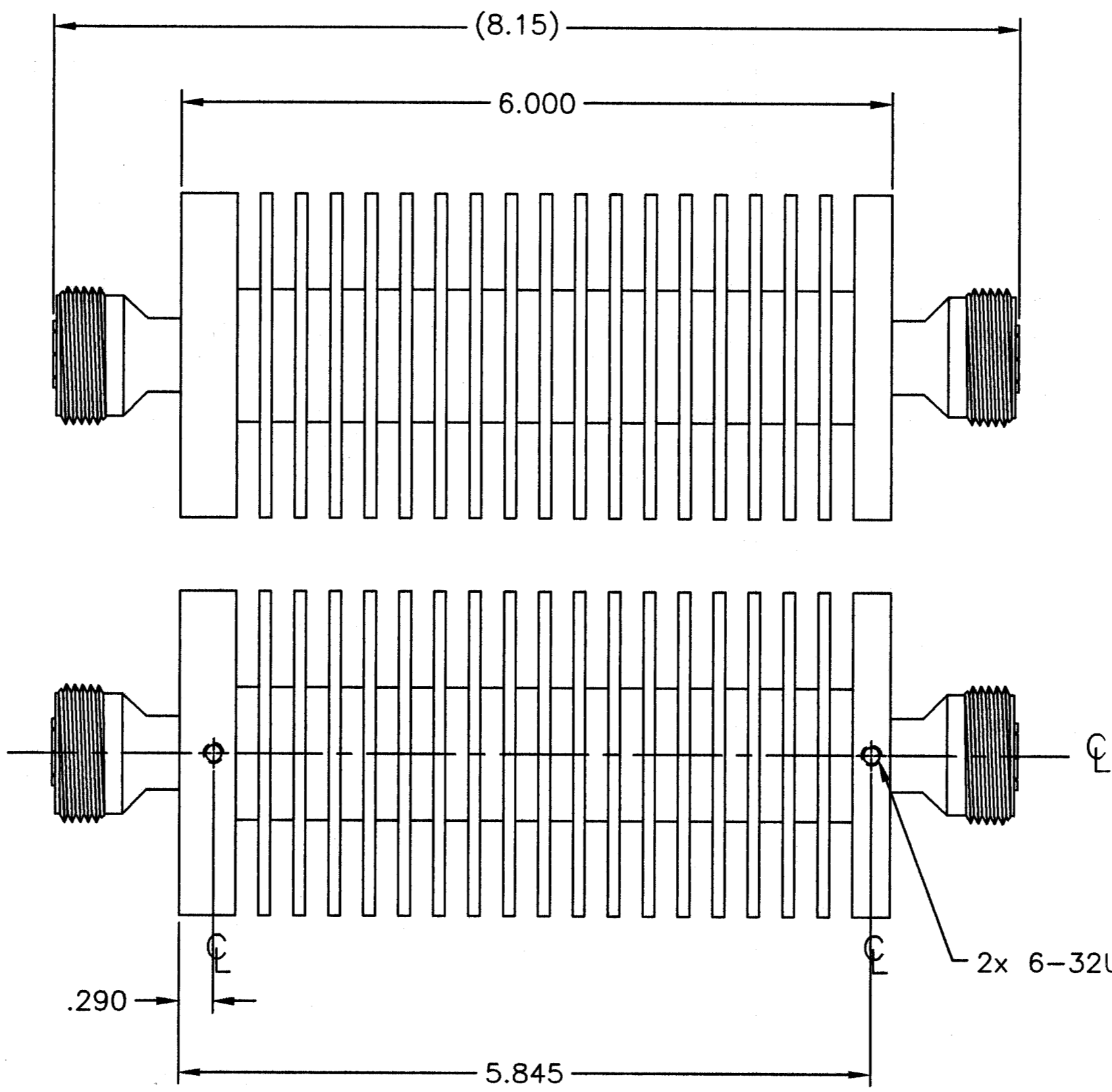
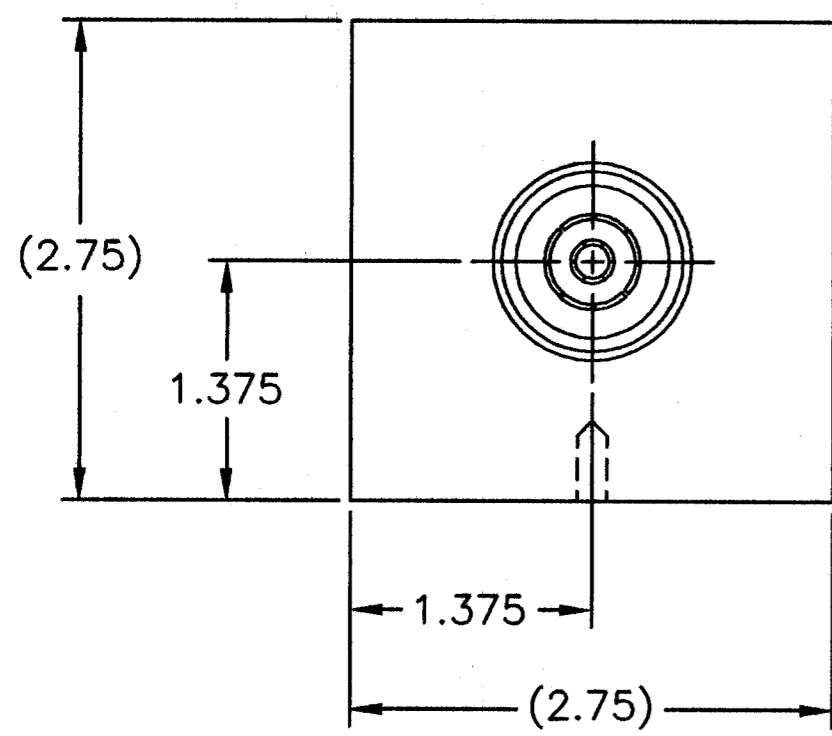

**NOTE:**  
 FOR VALUES NOT LISTED, REFER TO THE NEXT HIGHER ATTENUATION LEVEL FOR SPECIFICATIONS. FOR ATTENUATION VALUES GREATER THAN THE HIGHEST LISTED ATTENUATION VALUE, REFER TO THE VALUE 1/2 THE DESIRED ATTENUATION LEVEL, THEN DOUBLE THE LISTED SPECIFICATION VALUES, UNLESS OTHERWISE SPECIFIED.

XX = DASH NUMBER (dB VALUE)

-30	30	±0.8 dB	±1.3 dB
-20	20	±0.5 dB	±1.0 dB
-10	10	±0.4 dB	±0.8 dB
-06	6	±0.4 dB	±0.6 dB
-03	3	±0.3 dB	±0.5 dB
-02	2	±0.3 dB	±0.5 dB
-01	1	±0.3 dB	±0.5 dB
DASH NO.	dB ATTEN.	DC - 1GHz ATTENUATOR	1 - 2.4GHz ACCURACY ±dB

- NOTES:**
- ☒ 1. PART MUST BE BURR FREE.
  - ☒ 2. CHAMFER 1st THREAD.
  - ☒ 3. 63 MICRINCH UNLESS OTHERWISE SPECIFIED.
  - ☐ 4. PER BPS
  - ☒ 5. .005 RADIUS ON ALL INSIDE & OUTSIDE CORNERS UNLESS OTHERWISE SPECIFIED.

UNLESS OTHERWISE SPECIFIED DIMENSIONS ARE IN INCHES TOLERANCES ARE: FRACTIONS DECIMALS ANGLES ± 1/64 .005 ± .010 ± 30° DO NOT SCALE DRAWING	MILLIMETERS XX = ±.4 JXX = ±.12	THIS DRAWING IS THE PROPERTY OF THE BIRD ELECTRONIC CORPORATION. THE DESIGNS AND SPECIFICATIONS DISCLOSED HEREON ARE PROPRIETARY AND SHALL NOT BE REPRODUCED, NOR COPIED, NOR USED AS THE BASIS FOR THE MANUFACTURE OR SALE OF APPARATUS OR DEVICES WITHOUT THEIR EXPRESS WRITTEN CONSENT.	
MATERIAL	APPROVALS	DATE	TITLE
FINISH	D.M.RINK	3-4-03	ATTENUATOR, AXIAL, CONVECTION COOLED IEC 7/16 FEMALE/FEMALE, 100W
	CHECKED		SIZE FSCM NO. DWG. NO. REV
	APPROVED MAJ	6-15-03	C 70998 100-SA-FFE-XX A
		AUTOCAD	SCALE 1:1 COMM CODE AT1 SHEET 1 OF 1

DIMENSIONS HEREON ARE FOR CUSTOMER CONVENIENCE AND REFERENCE ONLY. TOLERANCE TO BE APPLIED ONLY WHERE INDIVIDUALLY STATED ON THE RESPECTIVE DIMENSION. -DO NOT SCALE DRAWING-

4 3 2 1